



**2x2 HDMI
Switcher**
USER MANUAL

www.gefen.com

ASKING FOR ASSISTANCE

Technical Support:

Telephone (818) 772-9100
(800) 545-6900

Fax (818) 772-9120

Technical Support Hours:

8:00 AM to 5:00 PM Monday through Friday.

Write To:

Gefen Inc.
c/o Customer Service
20600 Nordhoff St.
Chatsworth, CA 91311

www.gefen.com
support@gefen.com

Notice

Gefen Inc. reserves the right to make changes in the hardware, packaging and any accompanying documentation without prior written notice.

2x2 Switcher for HDMI is a trademark of Gefen Inc.
HDMI is a trademark of hdmi.org

TABLE OF CONTENTS

- 1 Introduction**
- 2 Features**
- 3 Panel Descriptions**
- 4 Connecting and Operating the 2x2 Switcher for HDMI**
- 5 RMT-2IR Installation**
- 6 IR Code Conflicts**
- 7 EDID Management Feature**
- 8 EDID management Modes**
- 9 RS-232 Serial Communication**
- 10 RS-232 Serial Communication Commands**
- 11 Specifications**
- 12 Warranty**

INTRODUCTION

Congratulations on your purchase of the Gefen 2x2 Switcher for HDMI. Your complete satisfaction is very important to us.

Gefen's line of HDTV switches, extenders, and splitters are designed to make your A/V equipment use more comfortable, more productive and less expensive.

The 2x2 Switcher for HDMI allows access to two HDTV devices, using two HDTV displays. Both output displays will have mirrored images. Also included is a TOSLINK output that will output the digital audio signal in audio form.

The Gefen line offers solutions for Home Theater, A/V installation, noise, space and security concerns, data center, information distribution, conference room presentation, school and corporate training environments.

Our Commitment

Gefen will always offer the finest quality product at the best possible price. Included in that price is a lifetime support from a team of outstanding engineers.

The Gefen 2x2 Switcher for HDMI allows two HDTV HDMI devices to be switched easily in to two HDTV HDMI compatible monitors or projectors. Simply connect your HDTV displays to the Switcher's display outputs. The 2x2 Switcher for HDMI can also be placed at the end of a long HDMI cable to regenerate the HDMI signal.

FEATURES

Features

- Switches easily between any two HDMI sources
- Maintains 480p, 720p, 720i, and 1080i, 1080p resolutions
- Maintains highest HDMI single link video resolution
- Maintains highest HDMI digital audio signal
- Includes Toslink output for easy hookup to digital audio systems
- Supports HDCP compliant devices
- Fully HDMI 1.2 compliant
- HDMI or DVI to HDMI cables are used to connect the inputs and switcher output
- Inputs can be switched with the IR remote control
- RS-232 Controllable
- Installs in seconds

Includes:

- (1) 2x2 Switcher for HDMI
- (2) 6' HDMI cables (M-M)
- (1) 5VDC Power Supply
- (1) RMT-2IR

PANEL DESCRIPTIONS

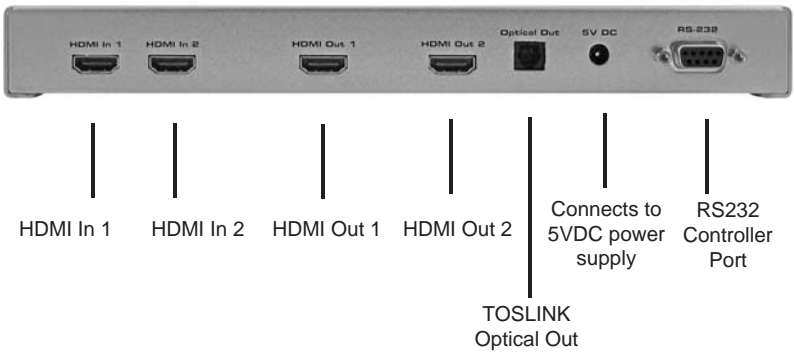
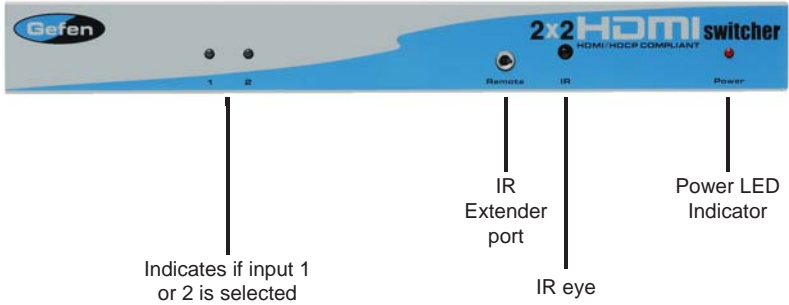

CONNECTING AND OPERATING THE 2X2 SWITCHER FOR HDMI

How to Connect the 2x2 Switcher for HDMI to your devices

- 1** Connect the supplied cables from the HDTV sources into the 2x2 Switcher for HDMI inputs.
- 2** Connect the cable from your display (monitor or projector) into the HDMI outs of the 2x2 Switcher for HDMI.
- 3** Connect any Digital Audio System into the OPTICAL out of the 2x2 Switcher for HDMI
- 3** Plug the 5VDC power supply into the 2x2 HD Switcher.

How to Control the 2x2 Switcher for HDMI

Use the RMT-2IR remote control to toggle between sources.

RMT-2IR INSTALLATION

1. Remove battery cover from the back of the RMT-2IR remote.
2. Verify that dip switches 1 & 2 are in the down (OFF) position.
3. Insert the battery, hold the battery so that you can see the positive side facing up. The side that is not marked must be facing down.
4. Test the RMT-2IR remote by pressing ONLY one button at a time. The indicator light on the remote will flash once each time you press a button. **WARNING:** Do not press multiple buttons simultaneously and do NOT press buttons rapidly. These actions will cause the remote to reset and steps 1-4 will have to be repeated.

Note: The RMT-2IR ships with two batteries. One battery is required for operation, the second battery is complimentary.



IR CODE CONFLICTS

Why would I need to change the remote channel?

In some instances, the 2x2 Switcher for HDMI may use IR codes that conflict with other IR remote control devices. The unit may switch inputs when another brand IR remote control is used or the RMT-2IR may cause other brand IR controlled devices to behave unexpectedly.

I am experiencing the issues listed above. What do I do?

In these cases it is recommended to change the IR channel that the RMT-2IR remote control and the 2x2 Switcher for HDMI use. The IR channel is configured independently on the RMT-2IR remote control and the 2x2 Switcher for HDMI but the channel selection must match on both units for proper operation.

How Do I change the Remote Channel?

There are service DIP switches on the RMT-2IR remote control and also inside the 2x2 Switcher for HDMI. Use the diagrams below to locate and change the IR channel to one that is not the default. Remember that the channel must match on both the unit and remote control for successful operation.

RMT-2IR Remote Control

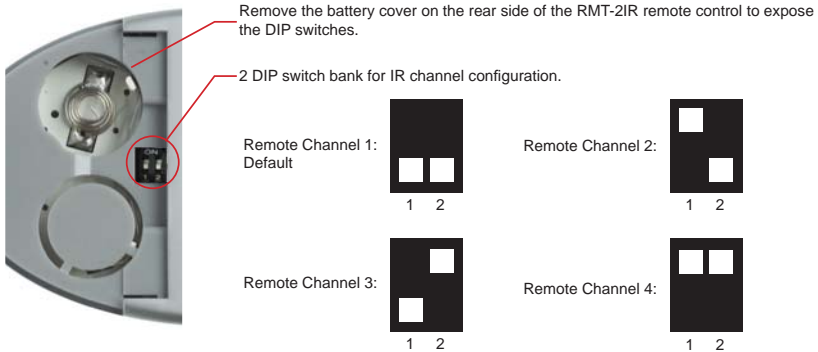

2x2 Switcher for HDMI

The IR channel DIP switches for the 2x2 Switcher for HDMI are located on an 8 bank DIP switch inside of the unit and on its main-board. To open the unit, remove all screws on the underside and side of the unit. Remove all HEX screws on the rear panel. This includes the screws above each HDMI port and on each side of the RS-232 serial communications port. Carefully slide the unit apart. Locate DIP switches 3 and 4. Once adjustments are complete replace all screws and.

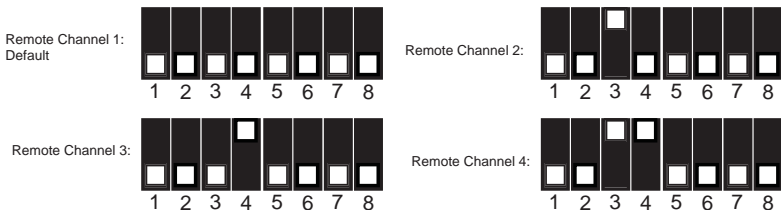

EDID MANAGEMENT FEATURE

EDID. What is it and what is it used for?

Under normal circumstances, an source device (digital and analog) will require information about a connected device/display to assess what resolutions and features are available. The source can then cater its output to send only resolutions and features that are compatible with the attached device/display. This information is called EDID (Extended Display Information Data) and a source device can only accept and read one EDID from a connected device/display. Likewise, the source can only output one resolution for use by a connected device/display.

Why is EDID so important with the 2x2 Switcher for HDMI?

The 2x2 Switcher for HDMI is complex piece of technology that replicates and switches between multiple inputs and outputs. Each connected source device will require one EDID to read. EDID management is carefully handled by 2x2 Switcher for HDMI to provide a single EDID for each source to read.

What options do I have to manage the EDID in the 2x2 Switcher for HDMI?

First, it is important to note that each source device can only output one video/audio signal type. This includes resolutions and timings. When multiple devices/displays are used, such as with the 2x2 Switcher for HDMI, it is important to use devices/displays that have similar or compatible resolutions/features. This will ensure that the single video/audio signal produced by the source device is accepted by all of the connected output devices/displays.

The user has the option, through a combination of DIP switch settings within the 2x2 Switcher for HDMI, to choose how the unit will manage the EDID from multiple HDMI devices/displays. Therefore the user has some control over the resolutions/features that the source devices will output. The 2x2 Switcher for HDMI has a multiple EDID management modes that will control how the EDID information from multiple devices/displays are combined, ignored, and routed.

How do I change EDID modes in the 2x2 Switcher for HDMI?

There is an bank of 8 DIP switches located on the main-board inside of the 2x2 Switcher for HDMI. DIP switches 1, 2, 5, and 7 are used in different combinations to manage the EDID modes.

TIP: EDID modes and IR code channels can also be managed via the RS-232 serial communications port. For this to work, all DIP switches must be in the OFF position. This is the factory default setting. If you wish to use this feature, please do not open the unit. See page 9 and 10 for more information on the RS-232 serial communication features.

To access these DIP switches it will be required to open the unit. To do this, remove all screws on the underside and side of the unit. Remove all HEX screws on the rear panel. This includes the screws above each HDMI port and on each side of the RS-232 serial communications port. Carefully slide the unit apart.

EDID Modes

The diagram below illustrates the 8 DIP switch bank.

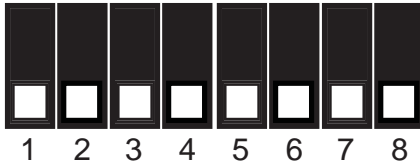

DIP SWITCH	Function
1	EDID Mode
2	EDID Mode
3	IR Channel
4	IR Channel
5	EDID Mode
6	N/A
7	EDID Mode
8	N/A

Use DIP switches 1, 2, 5, and 7 to select the desired EDID management mode.

EDID Mode 0 (Switch 1=OFF Switch2=OFF Switch5=ON)

- Edid is copied from the device connected to the first active hdmi output port.
- All features newer than HDMI 1.2 are cleared.

EDID Mode 1 (Switch 1=ON Switch2=OFF Switch5=ON)

- Same as Mode 0 and adds basic audio support.

EDID Mode 2 (Switch 1=OFF Switch2=ON Switch5=ON)

- Same as Mode 0 and adds full audio support.

EDID Mode 3 (Switch 1=ON Switch2=ON Switch5=OFF)

- EDID is generated based on the common video and audio features of all of the connected output devices.

EDID Mode 4 (Switch 1=OFF Switch2=ON Switch5=OFF)

- Same as Mode 3 and adds basic audio support.

EDID Mode 5 (Switch 1=ON Switch2=OFF Switch5=OFF)

- Same as Mode 3 and adds full audio support.

EDID Mode 6 (Switch 1=OFF Switch2=OFF Switch5=OFF) DEFAULT

- EDID is generated based on the common video features of all of the connected devices and the combined audio features of all of the connected output devices.

EDID Mode 7 (Switch 1=ON Switch2=ON Switch5=ON)

- EDID is passed unmodified from the device connected to the first active output port.

RS-232 SERIAL COMMUNICATION

What features are available via the RS-232 serial communications port?

The 2x2 Switcher for HDMI can accept commands through the RS-232 serial communications port located on the rear panel. The current RS-232 control features are:

- Switching/routing of inputs to outputs without the RMT-2IR remote control.
- Switch EDID management modes without opening the unit to physically modify DIP switches.
- Change IR code channel without opening the unit to physically modify DIP switches. (The IR code channel will still need to be manually modified on the RMT-2IR remote control to match the code channel.)

How do I use these features?

These features were initially intended for utilization by custom installers in automated setups. However, these features can be tested by using any Windows PC with the Hyperterminal program.

What pins are used for communication with the 2x2 Switcher for HDMI?

Only pins 2 (Receive), 3 (Transmit), and 5 (Ground) are used for communication. A null-modem adapter should not be used with this product.

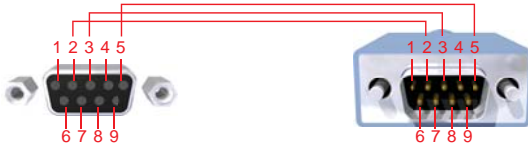

Only Pins 2 (RX), 3 (TX), and 5 (Ground) are used on the RS-232 serial interface

What are the communication port settings?

Bits per second	19200
Data bits	8
Parity	None
Stop bits	1
Flow Control	None

RS-232 SERIAL COMMUNICATION COMMANDS

Switching/Routing Binary Table

ASCII	RMT-2IR Button	Binary
1	1	0011 0001
2	2	0011 0010

EDID Management Modes

All DIP switches inside the unit must be in their default OFF position. Use the ASCII commands below to change the EDID modes. For a description of each mode please see page 8.

ASCII	EDID Mode
m0	0
m1	1
m2	2
m3	3
m4	4
m5	5
m6	6
m7	7

IR Remote Channel Configuration

All DIP switches inside the unit must be in their default OFF position. Use the ASCII commands below to change the IR code channel. Please ensure that the IR remote channel on the RMT-2IR matches any channel that is set by these commands. For a description of the IR code channel configuration please see page 6.

ASCII	Remote Channel
r1	1
r2	2
r3	3
r4	4

SPECIFICATIONS

Video Amplifier Bandwidth	1.65 GHz
Input Video Signal	1.2 volts p-p
Input DDC Signal	5 volts p-p (TTL)
Single Link Range1080p / 1920 x 1200
Input Connector Type	HDMI
Output Connector Type	HDMI
Output Audio Connector Type.....	...TOSLINK
Power Consumption	15 Watts (max.)
Power Supply	5VDC
Dimensions	10.25"W x 1.125"H x 4.25"D
Shipping Weight	6 Lbs